

# Quick-Lift Rail

QLR 200i



**Intelligent lifting device which meets the highest standards of ergonomics, working environment, safety and efficiency.**

Unique integrated mechanical, electrical, pneumatic swivel enables continuous rotation of gripper.

Easy to use, thanks to outstanding responsiveness, regardless of load weight.

Exceptional safety is achieved using our intelligent control systems.

High cost efficiency through low power consumption, high reliability and long durability.

# Quick-Lift Rail

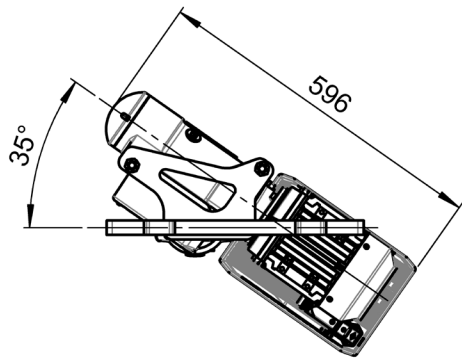
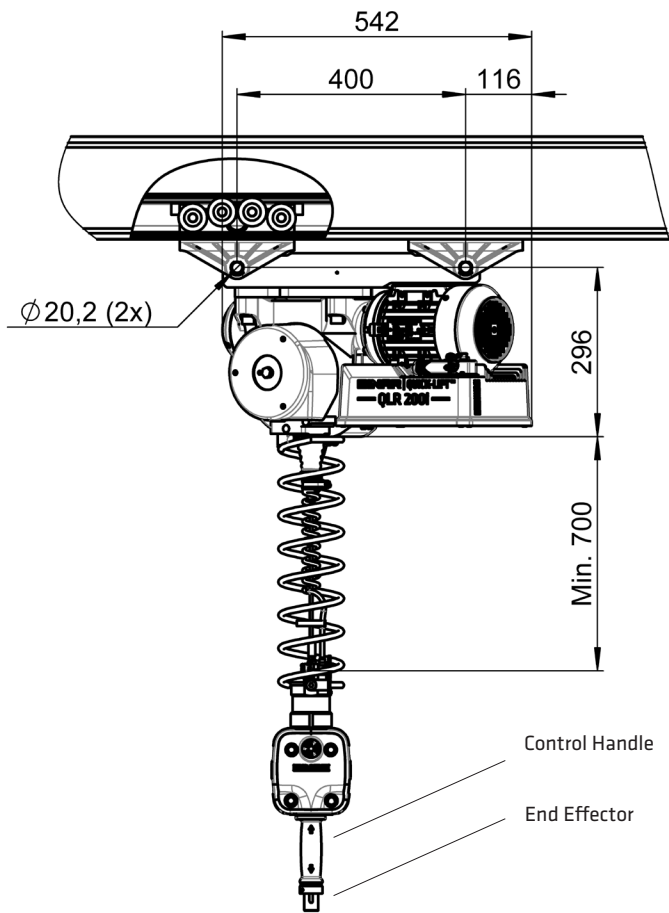

# QLR 200i

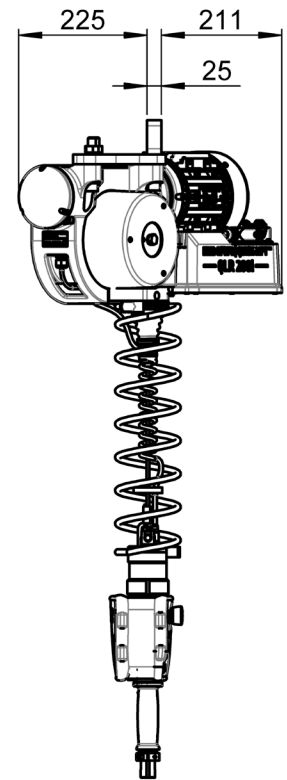

## TECHNICAL DATA QLR 200i

<b>Lifting capacity</b>	Max 200 kg
<b>Stroke length</b>	2,7 meter
<b>Lift motor</b>	Stepless servo-controlled asynchronous motor
<b>Weight</b>	41 kg
<b>Power supply</b>	230V, 50-60 Hz, 1-phase with ground protection, 10A
<b>Attachment</b>	The QLR 200i can be mounted in the most types of rail systems. Existing rail systems can often be used.
<b>Manoeuvring</b>	<p>Manoeuvring is done by using a patented control handle or balancing mode. Both options sense the operator's hand/arm movement and give a very exact and smooth speed control.</p> <p>Only a small force is needed to engage the up/down motion. When the operator let go of the handle, the up/down motion is immediately stopped.</p>
<b>End effector</b>	End effectors are designed to fit customer's need. Intelligent I/O signals are available for optimum functionality.

### Binar Quick-Lift Systems AB

Box 2014 • SE-461 11 TROLLHÄTTAN • Sweden  
 telephone: +46 (0)520 47 40 00 • e-mail: info.quicklift@binar.se  
 www.binarquicklift.com

2019-09-26 EN 3.0

**BINAR**  
*Improving your productivity*